

# User Manual

## REA Series Diode-Pumped Nd:YAG Rod Laser Modules

- REA-XX06
- REA-XX08
- REA-XX10
- REA-XX12



## Worldwide Technical Support and Product Information

[www.northropgrumman.com](http://www.northropgrumman.com)

Search ceolaser

Hours: 8:00 a.m. to 5:00 p.m., Central time\*

Service and Technical Support: (636) 916-4900 (follow prompts for department directory)

Email: [st-ceolaser-info@ngc.com](mailto:st-ceolaser-info@ngc.com)

## Cutting Edge Optronics Headquarters

20 Point West Blvd. St. Charles, MO 63301 USA

Sales Support: (636) 916-4900 (follow prompts for department directory)

\*After office hours, please leave a voice mail message. Outside North America, contact a Cutting Edge Optronics sales office or distributor; see the Cutting Edge Optronics website for a list of offices.

© 2006 - 2012 Cutting Edge Optronics, a division of Northrop Grumman Corporation. All rights reserved.

# Important Information

---

## Warranty Summary

Cutting Edge Optronics warrants that the products that it manufactures and sells will be free from defects in materials and workmanship for a period of one year from the date of shipment from an authorized Cutting Edge Optronics distributor. If a product proves defective within the respective period, Cutting Edge Optronics will provide repair or replacement as described in the complete warranty statement.

To arrange for service or obtain a copy of the complete warranty statement, please contact your nearest Cutting Edge Optronics sales and service office.

EXCEPT AS PROVIDED IN THIS SUMMARY OR THE APPLICABLE WARRANTY STATEMENT, CUTTING EDGE OPTRONICS MAKES NO WARRANTY OF ANY KIND, EXPRESS OR IMPLIED, INCLUDING WITHOUT LIMITATION THE IMPLIED WARRANTIES OF MERCHANTABILITY AND FITNESS FOR A PARTICULAR PUPOSE. IN NO EVENT SHALL CUTTING EDGE OPTRONICS BE LIABLE FOR INDIRECT, SPECIAL, OR CONSEQUENTIAL DAMAGES.

## Copyright

Under the copyright laws, this publication may not be reproduced or transmitted in any form, electronic or mechanical, including photocopying, recording, storing in an information retrieval system, or translating, in whole or in part, without the prior written consent of Cutting Edge Optronics.

## Trademarks

eDrive is a registered trademark of Northrop Grumman Corporation.

## Patents

Northrop Grumman Corporation products are covered by U.S. and foreign patents, issued and pending. Information in this publication supersedes that in all previously published material. Specifications and price change privileges reserved.

# Safety Information

## Product End-of-Life Handling



Cutting Edge Optronics is committed to protecting the environment. In accordance with the Waste Electrical and Electronic Equipment directive (WEEE) and Restriction of Hazardous Substances in the European Union (RoHS EU) directives, Cutting Edge Optronics accepts the return of our products for disposal. When you are ready to reclaim the instrument, you must properly transfer it according to local regulations concerning WEEE equipment. Contact Cutting Edge Optronics or your local distributor for shipping instructions. Please package the products as directed for a return for repair.

## ROC ROHS Declaration

In accordance with the Clause 6.2 of Marking for Control of Pollution Caused by Electronic Information Products (SJ/T11364:2006) for Measures for the Administration on Pollution Control of Electronic Information Products No. 39, Order of the Ministry of Information Industry of the Peoples Republic of China, Cutting Edge Optronics includes the following translation about our laser modules.

中华人民共和国，电子讯息产品管理办法：自我声明							
生产商		Northrop Grumman Cutting Edge Optronics					
生产商地址		20 Pointe West Blvd St. Charles, MO 63301 USA					
产品名称 / 编号		Mirus Series Laser Systems Models: MI-xxx-xxxx-xxxx and AMI-xxx-xxxx-xxxx					
有毒有害物质或元素标识表							
部件编号	部件名称	有毒有害物质或元素					
		铅 (Pb)	汞 (Hg)	镉 (Cd)	六价铬 (CrVI)	多溴联苯 (PBB)	多溴二苯醚 (PBDE)
第一组	外壳	○	○	○	○	○	○
第二组	电线/ 连接插头	X	○	X	X	X	X
第三组	安装组件	○	○	○	X	○	○
第四组	开关组件	○	○	○	X	X	X
第五组	电路板/ 开关组件	X	○	○	○	X	X
第六组	阵列前端次模组	○	○	○	○	○	○
第七组	接触板	X	○	○	○	X	X
第八组	热交换组件	○	○	○	○	○	○
第九组	16 进制硬件	○	○	X	○	○	○
第十组	焊锡	X	○	X	○	○	○
第十一组	电线/ 连接插头	X	○	○	○	X	X
第十二组	基部/ 端帽	X	○	○	X	○	○
第十三组	硬件/ 装配	○	○	○	X	○	○
第十四组	時計组件	X	○	○	X	X	X
第十五组	包装物料	○	○	○	○	○	○
O: 表示该有毒有害物质在该部件所有均质材料中的含量均在 SJ/T 11363-2006 规定的限量要求以下							
X: 表示该有毒有害物质至少在该部件的某一均质材料中的含量超出 SJ/T 11363-2006 规定的限量要求							

## Conventions

The following conventions appear in this manual:



This icon denotes a caution or a warning, which advise you of precautions to take to avoid injury, data loss, or a system crash.

---

**Initial Capped**



The first letter in uppercase refers to menu options, e.g., **Phase Delay**, **Pulse Width**.

---

**CAPS**

Front-panel buttons, knobs, and connectors appear in all uppercase letters, e.g., **MENU**, **CURRENT**.



The  symbol separates a sequence of button pushes, e.g., **MENU  CHANNEL SETUP  PULSE WIDTH** means that you push the **MENU** button, then push the **CHANNEL SETUP** soft key, and then push the **PULSE WIDTH** soft key.

---

*italic*

Italic text denotes references to other resources that may be helpful to you or to bring attention to important information.



This icon denotes a note, which alerts you to important information.



Power Switch Position Symbols

I = On   O = Off

The following conventions may appear on the product:

---

**DANGER**

An injury hazard immediately accessible as you read the marking.

---

**WARNING**

A hazard not immediately accessible as you read the marking.

---

**CAUTION**

A hazard to property including the product.



ESD: Handle Appropriately



Laser Emission: Use caution.

---



Shock Hazard: Use caution.

---



Caution: Risk of danger. Refer to manual.

---

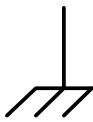

Chassis Ground

## General Safety Summary

The REA Series module emits laser radiation that can permanently damage eyes and skin, ignite fires, and vaporize substances. The Laser Safety section (Chapter 2) contains information and guidance about these hazards. To minimize the risk of injury or expensive repairs, carefully follow these instructions.

**Do not open the factory packaging before carefully reading this complete operation and maintenance manual.** If you have any questions on the product which have not been discussed sufficiently within the manual, contact the manufacturer for complete instructions. **Failure to heed this warning may result in the destruction or serious damage to the device, and will void the product warranty.**

The *Service* section is intended to help guide you to the source of problems. Do not attempt repairs while the unit is under warranty; instead, report all problems to Northrop Grumman Aerospace Systems Cutting Edge Optronics (NGAS CEO) for warranty repair.

Use the form in *Appendix A: Customer Service* to describe issues with the module. We also suggest that you record information about the module such as power, settings, time and date.

# About this Manual

---

This manual describes the installation, operation, and service of the REA Series module. The manual consists of the following chapters:

- *Chapter 1: Introduction* provides a theory of operation description of the module and specifications
- *Chapter 2: Laser Safety* describes proper safety procedures you should understand before operating the module.
- *Chapter 3: Module Details* provides information about unpacking, storing and proper environmental conditions for operation.
- *Chapter 4: Installation and Operation* discusses how to setup your module and powering on your system for the first time.
- *Chapter 5: Maintenance* provides information on proper maintenance of your module.
- *Chapter 6: Service* provides resources to help fix problems with the REA Series module
- *Appendix A: Customer Service* provides information to expedite any service request before contacting Cutting Edge Optronics.
- *Appendix B: System International Units* identifies commonly used units of measurement found in this manual.
- *Appendix C: Acronyms* provides a list of commonly used abbreviations and their descriptions used throughout this manual.



# Table of Contents

---

<b>Chapter 1: Introduction</b>	<b>1</b>
Theory of Operation	1
Temperature Tuning of Laser Diodes	2
REA-Series Description	3
High Voltage DC Power Supply	4
Closed Loop Re-circulating Distilled Water Chiller	4
Specifications	6
<b>Chapter 2: Laser Safety</b>	<b>8</b>
Caution & Warning Statements	9
Precautions for Safe Operation of Class IV Lasers	9
Center for Devices and Radiological Health (CDRH) OEM Product	10
Safety Device Checklist	11
<b>Chapter 3: Module Details</b>	<b>12</b>
Unpacking your Module	13
REA Series Module	13
REA Timer	15
Closed Loop Chiller	19
High Voltage DC Power Supply	23
<b>Chapter 4: Installation and Operation</b>	<b>25</b>
REA Series Laser Module Assembly and Connections	26
Closed Loop Water Chiller Assembly	28
Starting the Laser System	29

Standby Condition	31
Turning Off the System	31
<b>Chapter 5: Maintenance</b>	<b>32</b>
Rod Removal and Replacement	33
Rod Cleaning	37
Leak Test Procedure	37
Adjusting the Operating Current	38
Cleaning the Chiller	39
<b>Chapter 6: Service</b>	<b>41</b>
Contacting Customer Service	42
Return the Instrument for Repair	42
<b>Appendix A: Customer Service</b>	<b>43</b>
Questions	44
<b>Appendix B: System International Units</b>	<b>46</b>
<b>Appendix C: Acronyms</b>	<b>47</b>

# Table of Figures

---

<b>Figure 1-1</b> Exterior Components and Connections	1
<b>Figure 1-2</b> Nd:YAG Absorption Characteristics	2
<b>Figure 1-3</b> Pump Light Absorption vs. Pump Array Center Wavelength	3
<b>Figure 1-4</b> Radial Pump Geometry	3
<b>Table 1-1</b> REA Physical Configuration	4
<b>Table 1-2</b> End of life Waste Heat	5
<b>Table 1-3</b> REA Series Model Specifications <sup>1</sup>	6
<b>Table 1-4</b> REA Series General Specifications	7
<b>Figure 2-1</b> Standard Safety Warning Sign	10
<b>Figure 2-2</b> Radiation Control Drawing	11
<b>Figure 2-3</b> Warning Labels	11
<b>Figure 3-1</b> Reverse Bias Protection Diode Circuit	15
<b>Figure 3-2</b> REA Series Electronic Timer	16
<b>Table 3-1.</b> Cooling System Requirements	19
<b>Table 3-2.</b> Avoid with Chillers	20
<b>Figure 3-3.</b> Constant Dew Point Lines for Ambient Temperature and Relative Humidity	22
<b>Table 3-3.</b> Table of Air Condensation Temperature at Given Ambient Air Temperature (Celcius) and Relative Humidity (percent)	23
<b>Figure 4-1</b> Connection Diagram	27
<b>Figure 4-2</b> eDrive Rear Panel	27
<b>Figure 4-3</b> Chiller Assembly Drawing	28
<b>Figure 5-1</b> Rod Replacement Drawing, REA-XXXX-001X	33

<b>Figure 5-2</b> Rod Replacement Drawing, REA-XXXX-002X	35
<b>Figure 5-3</b> REA-XXXX-002X O-rings	36
<b>Figure 5-4</b> Nitrogen Leak Test Layout	38

---

# Chapter 1: Introduction

This introduction provides the following information:

- Theory of operation
- Temperature Tuning of Laser Diodes
- REA Series description
- High Voltage DC Power Supply
- Closed Loop Re-circulating Chiller
- Specifications

# Theory of Operation

The REA Series module was designed for use as a building block “engine” in the development or production of medium power rod laser systems or as a drop-in replacement for arc lamp pump chambers in industrial lasers. It is well suited for medium power applications such as laser marking, and can provide high stability and beam quality for more precise micro-machining and scientific applications.

Northrop Grumman Aerospace Systems Cutting Edge Optronics (NGAS CEO) diode pumped, solid-state lasers and pump modules use temperature-tuned GaAlAs laser diodes. These diodes replace arc lamps or incandescent light sources as the optical pump source. The principal advantages of this approach include:

- Longer lifetime
- More compact size
- More efficient operation

The REA-Series module uses arrays of solid-state laser diodes to optically pump a neodymium-doped yttrium aluminum garnet (Nd:YAG) lasing medium. The diode optical output power is radially coupled into the laser rod. The Nd:YAG laser rod has an anti-reflection coating chosen for the highest gain wavelength of this material, 1064 nm. The REA-Series module is constructed within a durable and rigid structure. Exterior components and connections are shown in Figure 1-1.

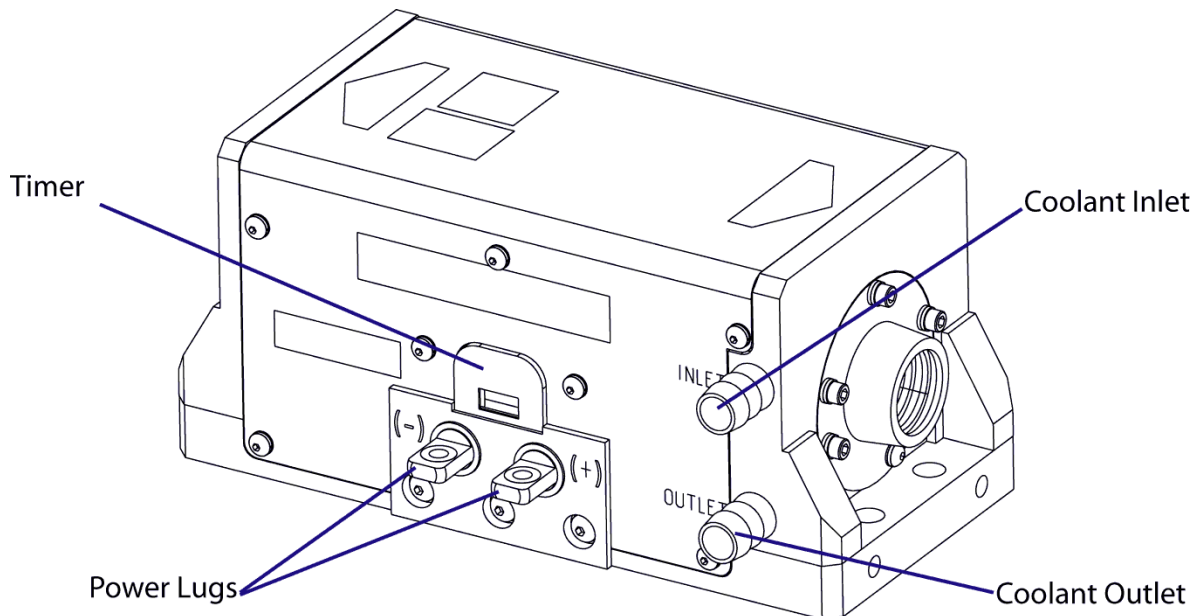

Figure 1-1 Exterior Components and Connections

## Temperature Tuning of Laser Diodes

The laser diodes are located within the REA-Series module and tuned, wavelength matched, via the closed loop chiller. For maximum efficiency, the diode output wavelength must match the laser medium absorption characteristics (see Figure 1-2). The output spectrum of a conventional pump source for Nd:YAG operation, the xenon arc lamp, and 808 nm diode array is also shown.

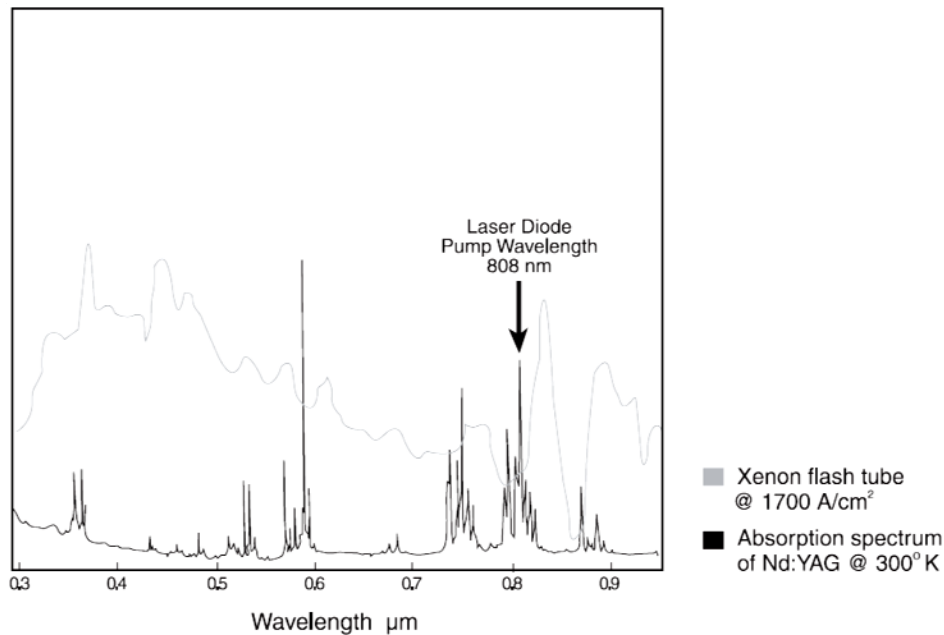

Figure 1-2 Nd:YAG Absorption Characteristics

A single GaAlAs laser diode bar has a 2 nm FWHM distribution of output wavelengths. However, the process used in the manufacture of GaAlAs laser diodes results in a peak output wavelength for each diode that fits within a 10 nm distribution of wavelengths from 800-810 nm. To match the diode output to an absorption peak of the laser medium, diodes are selected with similar peak output wavelengths within the manufacturing range. Temperature tuning is possible because GaAlAs diode characteristics are such that 0.25 nm of wavelength shift occurs for every 1°C change in temperature of the diode junction. Cooling shortens the wavelength, and heating lengthens it. Figure 1-3 shows the percentage of pump light of different wavelengths absorbed by two passes through a 6.35 mm thick rod of 0.6% doped Nd:YAG. In CEO modules, the laser diode center wavelength, under normal operating conditions, is near the absorption peak of the laser medium. The operating temperature of closed loop chiller is carefully chosen to shift the diode temperature, so that the wavelength matches the absorption peak. The final test report, included with each module, indicates the optimum operation temperature for that module.

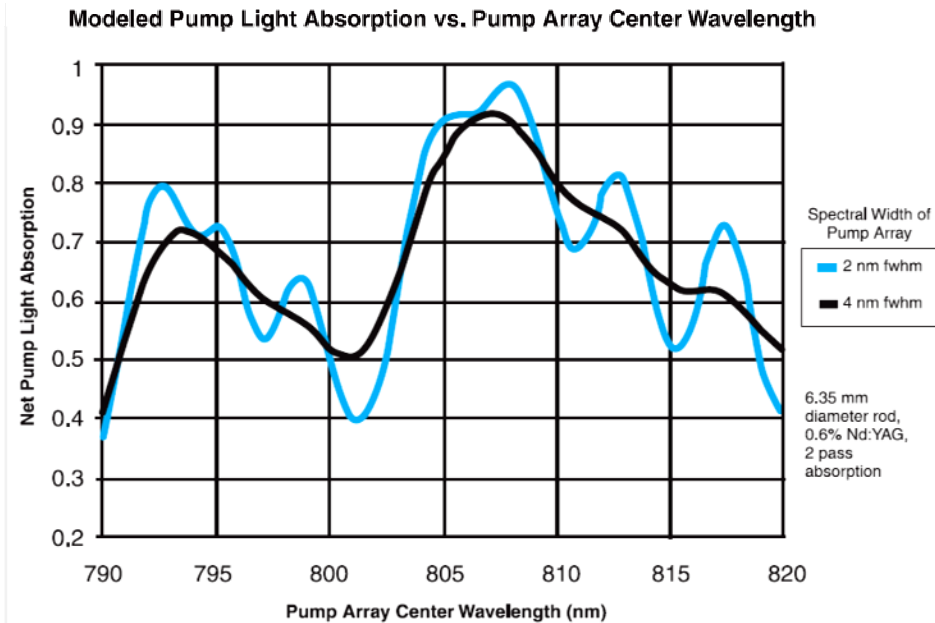

Figure 1-3 Pump Light Absorption vs. Pump Array Center Wavelength

## REA-Series Description

The REA-Series module utilizes a radial longitudinal pump geometry to excite the solid-state laser medium (see Figure 1-4). This pump geometry results in excellent gain uniformity and lensing performance. The reflector directs the divergent diode light back to the laser medium, which is kept in a flow tube for coolant circulation. The laser medium is a rod of neodymium-doped yttrium aluminum garnet (Nd:YAG). Both ends of the rod are optically polished and include anti reflection coatings at the lasing wavelength. The ends of the rod may be curved to compensate for thermal lensing, depending on module configuration.

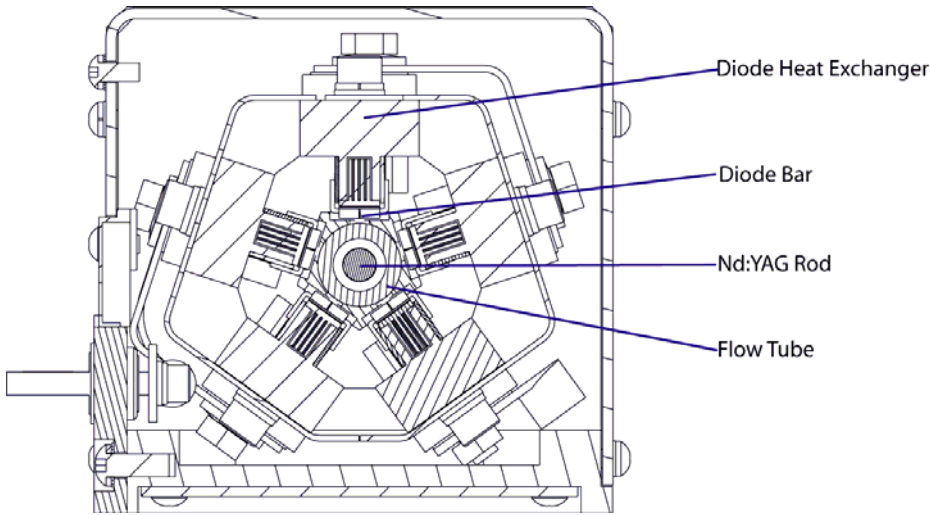

Figure 1-4 Radial Pump Geometry

The REA comes in various physical configurations per table 1-1. In addition, each of the models listed consists of 5 arrays per module.



Table 1-1 REA Physical Configuration

Model Number	Rod Diameter (mm)	Length (Inches)	Width (Inches)	Height (Inches)	Beam Height (Inches)	Bars per Array	Watts per Bar
REA4006	4.0	5.74	3.27	3.06	1.5	6	20 or 40
REA4008	4.0	6.55	3.27	3.06	1.5	8	20 or 40
REA5006	5.0	5.74	3.27	3.06	1.5	6	20 or 40
REA5008	5.0	6.55	3.27	3.06	1.5	8	20 or 40
REA5010	5.0	7.4	3.27	3.06	1.5	10	20 or 40
REA5012	5.0	8.23	3.27	3.06	1.5	12	20 or 40
REA6306	6.35	5.74	3.27	3.06	1.5	6	20 or 40
REA6308	6.35	6.55	3.27	3.06	1.5	8	20 or 40
REA6310	6.35	7.4	3.27	3.06	1.5	10	20 or 40
REA6312	6.35	8.23	3.27	3.06	1.5	12	20 or 40
REA7006	7.0	5.74	3.27	3.06	1.5	6	20 or 40
REA7008	7.0	6.55	3.27	3.06	1.5	8	20 or 40
REA7010	7.0	7.4	3.27	3.06	1.5	10	20 or 40
REA7012	7.0	8.23	3.27	3.06	1.5	12	20 or 40
REA8006	8.0	5.74	3.57	3.41	1.75	6	20 or 40
REA8008	8.0	6.55	3.57	3.41	1.75	8	20 or 40
REA8010	8.0	7.4	3.57	3.41	1.75	10	20 or 40
REA8012	8.0	8.23	3.57	3.41	1.75	12	20 or 40
REA9006	9.0	5.74	3.57	3.41	1.75	6	20 or 40
REA9008	9.0	6.55	3.57	3.41	1.75	8	20 or 40
REA9010	9.0	7.4	3.57	3.41	1.75	10	20 or 40
REA9012	9.0	8.23	3.57	3.41	1.75	12	20 or 40
REA10006	10.0	5.74	3.57	3.41	1.75	6	20 or 40
REA10008	10.0	6.55	3.57	3.41	1.75	8	20 or 40
REA10010	10.0	7.4	3.57	3.41	1.75	10	20 or 40
REA10012	10.0	8.23	3.57	3.41	1.75	12	20 or 40

## High Voltage DC Power Supply

---

A high voltage DC power supply is required to provide the DC voltage to run the diode arrays in an REA-Series module. CEO will recommend a power supply based on the customer's application.

## Closed Loop Re-circulating Distilled Water Chiller

---

Coolant flow direction is polarized on the REA-Series pump module. Inlet and Outlet hose barbs are marked on the pumphead. Be sure to connect the coolant filter for the selected chiller on the Inlet connection, so only clean coolant from the filter flows through the pumphead. Dirty coolant deposits dirt on the laser rod, which results in low output power.

The module coolant loop is designed for an operating pressure of 50 psi. The selected chiller must have a heat capacity of greater than the power consumption for the specific model of REA-Series module. Table 1-2 gives the CEO end of life operating current and power consumption (waste heat).

Table 1-2 End of life Waste Heat

<b>60 Hz Electrical Outlets</b>				
Model	EOL Current	Waste Heat	Polyscience Chiller No.	Chiller Capacity
REAXX06-1C2H	32 A	1920W	6762T41CE30D	2500 W
REAXX06-1C4H	50 A	3000W	6162T41CE30D	2900 W
REAXX08-1C2H	32 A	2560W	6162T41CE30D	2900 W
REAXX08-1C4H	50 A	4000W	6862T66CE70D	5200 W
REAXX10-1C2H	32 A	3200W	6162T41CE30D	2900 W
REAXX10-1C4H	50 A	5000W	6862T66CE70D	5200 W
REAXX12-1C2H	32 A	3840W	6862T66CE70D	5200 W
REAXX12-1C4H	50 A	6000W	Contact CEO	Contact CEO
<b>50 Hz Electrical Outlets</b>				
Model	EOL Current	Waste Heat	Polyscience Chiller No.	Chiller Capacity
REAXX06-1C2H	32 A	1920W	6752T41CE30E	2075 W
REAXX06-1C4H	50 A	3000W	6852T66CE70E	4316 W
REAXX08-1C2H	32 A	2560W	6852T66CE70E	4316 W
REAXX08-1C4H	50 A	4000W	6852T66CE70E	4316 W
REAXX10-1C2H	32 A	3200W	6852T66CE70E	4316 W
REAXX10-1C4H	50 A	5000W	Contact CEO	Contact CEO
REAXX12-1C2H	32 A	3840W	6852T66CE70E	4316 W
REAXX12-1C4H	50 A	6000W	Contact CEO	Contact CEO

# Specifications

REA-Series modules are tested to exceed the following specifications. The standard production test configuration consists of a  $280 \pm 5$  mm cavity utilizing a flat high reflector and a flat 70% reflective output coupler. The modules are run at normal drive current of 25 A for 1C2H and 40 A for 1C4H.

Table 1-3 REA Series Model Specifications<sup>1</sup>

Model Number	Bars per Array	Watts per Bar	Diode Bias Voltage	Power Consumption <sup>2</sup> (20 Watt bar)	Power Consumption <sup>2</sup> (40 Watt bar)
REA4006	6	20 or 40	60	1920	3000
REA4008	8	20 or 40	80	2560	4000
REA5006	6	20 or 40	60	1920	3000
REA5008	8	20 or 40	80	2560	4000
REA5010	10	20 or 40	100	3200	5000
REA5012	12	20 or 40	120	3840	6000
REA6306	6	20 or 40	60	1920	3000
REA6308	8	20 or 40	80	2560	4000
REA6310	10	20 or 40	100	3200	5000
REA6312	12	20 or 40	120	3840	6000
REA7006	6	20 or 40	60	1920	3000
REA7008	8	20 or 40	80	2560	4000
REA7010	10	20 or 40	100	3200	5000
REA7012	12	20 or 40	120	3840	6000
REA8006	6	20 or 40	60	1920	3000
REA8008	8	20 or 40	80	2560	4000
REA8010	10	20 or 40	100	3200	5000
REA8012	12	20 or 40	120	3840	6000
REA9006	6	20 or 40	60	1920	3000
REA9008	8	20 or 40	80	2560	4000
REA9010	10	20 or 40	100	3200	5000
REA9012	12	20 or 40	120	3840	6000
REA10006	6	20 or 40	60	1920	3000
REA10008	8	20 or 40	80	2560	4000
REA10010	10	20 or 40	100	3200	5000
REA10012	12	20 or 40	120	3840	6000

<sup>1</sup>Specifications subject to change without notice

<sup>2</sup>At end of life operating current is 32A for 1C2H and 50A for 1C4H

Table 1-4 REA Series General Specifications

<b>All REA-Series Models</b>	
Type	CW Diode Pumped Nd:YAG Rod <sup>1, 4</sup>
Dopant Level	Application Dependent
Output Wavelength	1064 nm
Polarization	Random
Cooling	Closed Loop Recycling Coolant <sup>2</sup>
Coolant Flow	> 2.0 GPM
Coolant Pressure <sup>3</sup>	50 PSI
Operating Temperature	20-30 °C non-condensing

<sup>1</sup>The Continuous wave diode arrays are sensitive to excessive thermal cycling. Current should not be turned off completely and then restored to full operating current more than 6 times per day. Current should be gradually (~1A/s) ramped up when operating current restored. See chapter 3 for more details.

<sup>2</sup>CEO recommends Optishield Plus<sub>TM</sub> /distilled water coolant (10% Optishield Plus<sub>TM</sub>, 90% distilled water).

<sup>3</sup>CEO modules are leak tested to 80 psi with Nitrogen gas. CEO recommends 50 psi of chiller water for actual operation

<sup>4</sup> YLF configurations are available by special request

---

## Chapter 2: Laser Safety

Please read this section carefully before installing or operating your REA Series module. We recommend that all service and repair operations be performed by a NGAS Cutting Edge Optronics service engineer. If you do plan to service your laser module, please follow the procedures in the Service section of this manual.

Sections included in this chapter provide the following information:

- Caution & Warning Statements
- Precautions for Safe Operation of Class IV Lasers
- Center for Devices and Radiological Health (CDRH) OEM Product
- Safety Device Checklist

## Caution & Warning Statements

---



**WARNING** The NGAS Cutting Edge Optronics REA Series component when used as a laser oscillator is a Class IV-High Power Laser whose beam is, by definition, a safety hazard. Avoid eye or skin exposure to direct or scattered laser radiation. Avoid direct viewing of the beam or its specular reflection. When energized, a large amount of high power invisible laser radiation is emitted from the laser module.

Follow instructions contained in this manual for proper installation and safe operation of your laser. We recommend the use of protective eyewear at all times; selection depends on the energy and wavelength of the laser beam as well as operating conditions. Consult ANSI, ACGIH, or OSHA standards for guidance.



**WARNING** Use of controls, adjustments or performance of procedures other than those specified herein may result in hazardous radiation exposure.



**WARNING** At all times during installation, operation, maintenance, or service of your laser, avoid exposure to laser or collateral radiation exceeding the accessible emission limits listed in "Performance Standards for Laser Products," United States Code of Federal Regulations, 21 CFR 1040.10(d).



**ESD CAUTION** The laser diodes in the REA Series are sensitive to Electro-Static Discharge (ESD). Never handle the REA Series module without being properly grounded through the use of properly installed and maintained grounding wrist straps or other ESD control devices. Subjecting the REA Series to static shock can seriously damage or destroy the diode bars, and will void the product warranty.



**ELECTRICAL WARNING** The voltages in this system can be harmful or even lethal. Whenever handling or servicing the laser, always disconnect the power cord to the power supplies and drivers. Use a voltmeter to verify all electronics are discharged before touching or grounding of electrical connections.

## Precautions for Safe Operation of Class IV Lasers

---

- Never look directly into the laser beam or at specular reflection, even with protective eye-wear on.
- Always wear laser safety eye-wear that is appropriate for the output power at the wavelengths of operation (808 nm pump light and 1064 nm fundamental).
- Set aside a controlled-access area for laser operation; limit access to those trained in the principles of laser safety.
- Post readily readable warning signs in prominent locations near the laser operation area.

- Use safety interlocks on all entryways. All NGAS CEO system control electronics are provided with interlock inputs to preclude operation with an open safety door. NOTE: when multiple interlocks are used, they must be connected in SERIES for proper function.
- Restrict access to laser areas to those who have been instructed in the necessary safety precautions.
- Enclose beam paths wherever possible.
- Set up experiments so the laser beam is below eye level.
- Work in an area that is well lit to avoid dilation of pupils.
- Set up a target for the beam.
- Set up shields to prevent reflected beams from escaping the laser operation area.
- The Q-switched output power of the laser emits extremely high peak optical powers, powers that can severely damage a wide array of optical components and detectors. Know the limits of your components before exposing them to the Q-switched beam.
- View an infrared laser beam with a protected image converter at an oblique angle reflecting from a diffuse surface. Do not use phosphorus cards in the Q-switched beam.
- Ensure that all electrical connections are made in a safe manner.
- Where possible, position equipment so that electrical connections are shielded from accidental touch.
- No smoking, eating, or drinking should be allowed in laser areas.
- Never leave an operating laser unattended.

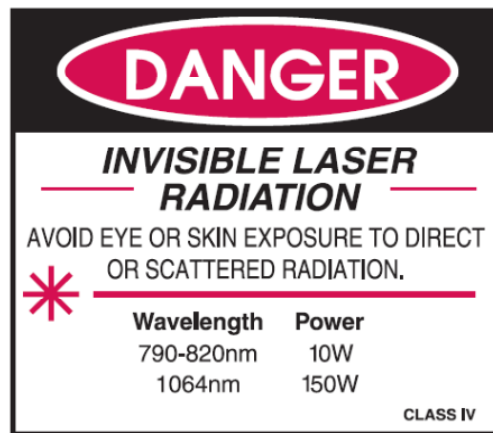

Figure 2-1 Standard Safety Warning Sign

## Center for Devices and Radiological Health (CDRH) OEM Product

The REA-Series module is considered a component according to the Food and Drug Administration, Code of Federal Regulations Title 21, Section 1002.1(b) for use in

an end system, and therefore does not fully comply with all the requirements of the Code of Federal Regulations for laser-based systems. The REA-Series module is capable of emitting Class IV radiation, and extreme care must be exercised in its installation and operation. Only persons familiar with the safety precautions and practices in this manual should operate the laser product.

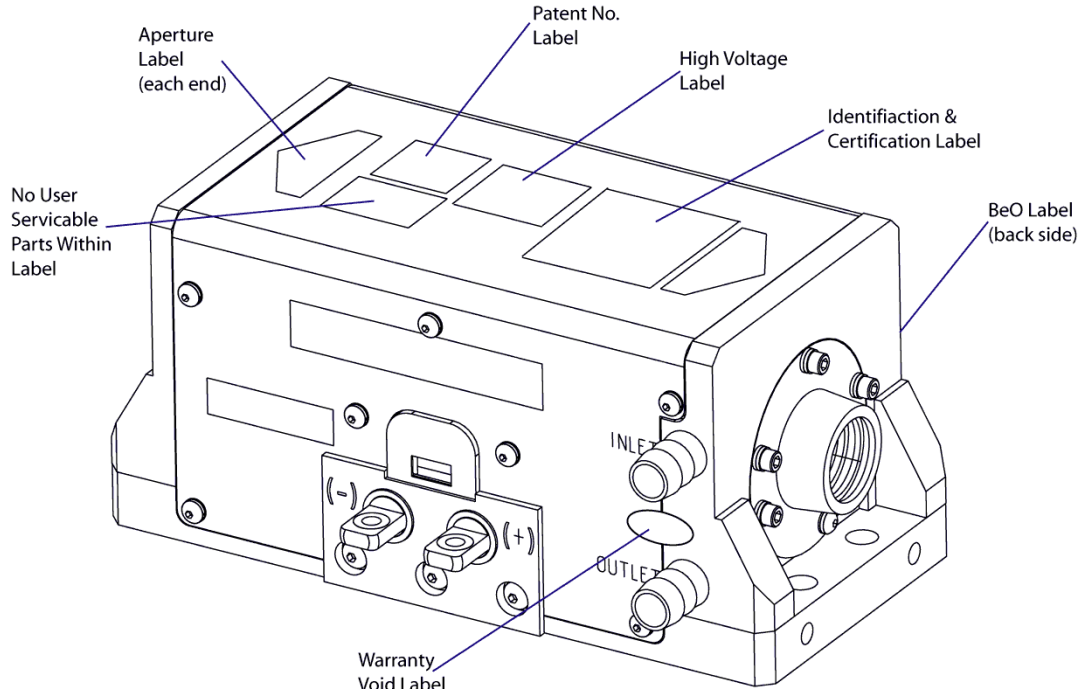

Figure 2-2 Radiation Control Drawing



Figure 2-3 Warning Labels

## Safety Device Checklist

1. Verify that all labels are securely affixed.
2. Verify that the safety interlock system is working properly.
3. Locate the module so that operation of laser and/or adjustr electronics do not require exposure to laser radiation.



---

## Chapter 3: Module Details

This chapter describes basic operation of your REA Series module. This chapter discusses:

- Unpacking your Module
- REA Series Module
- REA Timer
- Closed Loop Chiller
- High Voltage DC Power Supply

## Unpacking your Module

---

Your NGAS Cutting Edge Optronics Model REA Series module was carefully packed for shipment. If the carton appears to have been damaged in transit, have the shipper's agent present when you unpack.



**CAUTION** The module is susceptible to damage due to electro-static discharge (ESD). Always use proper ESD control devices when handling the module.



**CAUTION** Do not open sealed package until package has normalized to room temperature. Condensation can seriously damage the diode arrays in the laser module and may void warranty.

Inspect the unit as you unpack it, looking for dents, scratches, or other evidence of damage. If you discover any damage, immediately file a claim against the carrier and notify your NGAS CEO representative. NGAS CEO will arrange for repair without waiting for settlement of your claim.

Keep the shipping container. If you file a damage claim, you may need it to demonstrate that the damage occurred as a result of shipping. If you need to return the unit for service, the specially designed carton assures adequate protection. A manual and a final test report should accompany each unit shipped.

## REA Series Module

---

Proper storage of the REA Series module involves four steps:

1. Remove all coolant from module by blowing dry air through it for 20 minutes.
2. Place a shorting connector across the module electrical contacts.
3. Install rod end covers over both beam tube supports.
4. Store module in a clean, dry atmosphere (relative humidity less than 30%). If necessary, place module in a sealed bag with some form of desiccant.

The approximate diode bias voltage for the different models of REA-Series module can be found in the Specifications table at the end of chapter one. The electrical system should deliver approximately 10 more volts, depending on the FET used. The final test report shipped with the REA-Series module indicates the beginning of life current required to obtain the module's rated output power in a short cavity test. NGAS CEO recommends users not exceed the listed current, as overdriving the module reduces diode lifetime.

The REA-Series module connects to a diode driver in via power lugs on the base of the pumphead module.

REA-Series module output is a result of the optical pump power from the continuous wave laser diodes. These *continuous* wave diodes are sensitive to thermal shock from repeatedly applying and removing drive current. Diodes should not be cycled on/off more than 6 times a day. When initially applying power to the module, the current should be gradually increased ( $\sim 3$  A/s) until the normal operating current is achieved (see final test report for initial recommended operating current). This “ramping” process reduces thermal shock and helps prolong diode lifetime. If the REA module is going to be installed in a system where quick transitions between lasing and non-lasing are repeatedly required, then drive current to the diodes should be maintained at  $\sim 3$  A below normal operating current when the system is not lasing. This “simmer” current will keep the diodes at close to the operating (lasing) temperature and thereby reduce thermal shock.

The diode arrays within the REA-Series module are aligned and sealed at the factory. Other than the laser rod, there are no user serviceable parts within the module. Contact a NGAS CEO field service engineer for repairs. Before lasing, the operator should verify that rod faces are clean. If necessary, the rod faces can be cleaned by following the procedure in the maintenance section of this manual.

## Reverse Bias Protection

Diodes are polarized with respect to electrical flow. A forward biased diode readily conducts; while a reverse biased diode blocks conduction. If sufficient voltage is applied in the reverse direction, the diode is permanently damaged. Laser diodes are the single most expensive component of a REA Series module, so the customer should be careful to connect diode drive current correctly.

In order to provide the REA Series modules with some protection against reverse biasing, all REA Series modules are equipped with a reverse protection diode. This is another diode, usually located in the module, which forms a circuit across the laser diode arrays in the opposite flow direction (Figure 3-1). In the event of the laser diode drive current being reversed, the reverse bias protection diode will act like a short circuit, allowing the electricity to flow for a brief time with no resistance. However, the reverse bias protection diode is not able to withstand the high currents that laser diodes require. The protection diode will burn out after a brief time, and the drive current will be sent through the laser diodes in reverse.

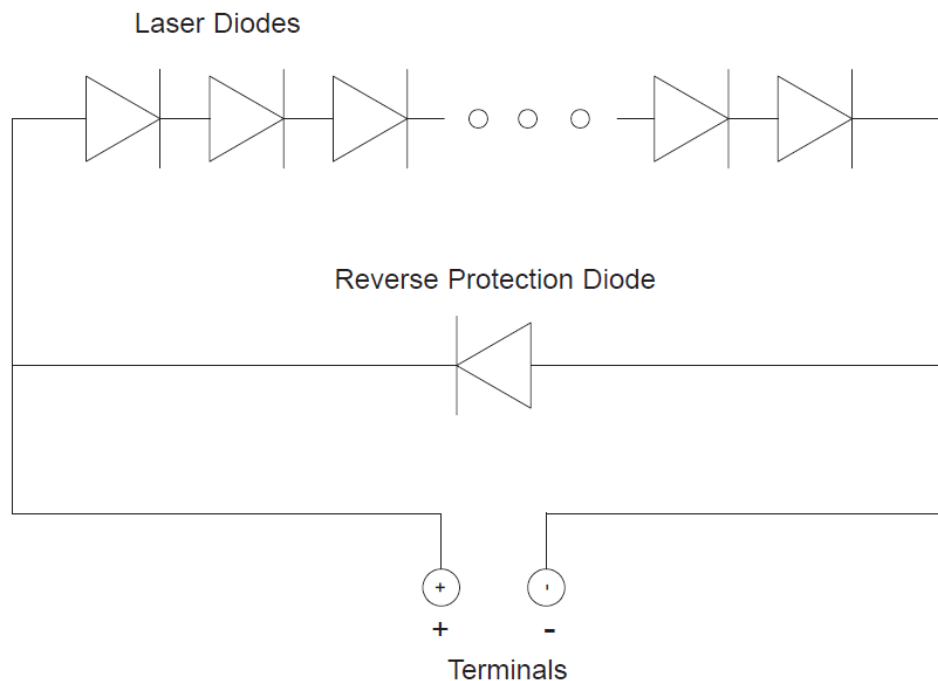

Figure 3-1 Reverse Bias Protection Diode Circuit

NGAS CEO drive electronics are designed to detect the shorted reverse protection diode, and suspend drive current before damaging the laser diodes. Customers who use third party manufactured drive electronics must configure them for use with NGAS CEOs reverse bias protection diodes. The driver should be able to detect the shorted condition because with a short across the array, the full power supply voltage will suddenly be impressed across the driver control FETs. For drivers which have a fixed power supply voltage, a much larger voltage across the drive FETs will increase the heat load and cause a dramatic rise in their temperature. For third-party drivers which have the capability to servo the voltage to produce the necessary current, a sudden decrease in output voltage should cause a corresponding large decrease in the voltage required internally within the driver, which could be detected and reported. If any of the conditions are detected, the driver should suspend diode drive current and send the operator an error message.

## REA Timer

---

The REA Series module includes an electronic timer circuit which monitors the operation of the pump head and tracks the number of hours of operation, the number of pulsed shots, and the number of on/off cycles over the lifetime of the head. These data may be displayed to the user on a 4-digit LCD display on the front of the module. This timer is powered by the applied module operating voltage and will only be operational when the module is operating.



Timer LCD Readout

Figure 3-2 REA Series Electronic Timer

When the module is powered on, the timer will startup and displays two startup readings. After these readings have been displayed, the timer transitions into a looping operational display mode in which operating values are repeatedly displayed. These modes are described below.

## Startup Display

On startup, the timer will display a 4-digit software revision number. This number will be underlined and the digits are decoded as follows:

Digit 1: Major Revision Level

Digit 2: Minor Revision Level

Digits 3-4: Build Number

An example is shown below:

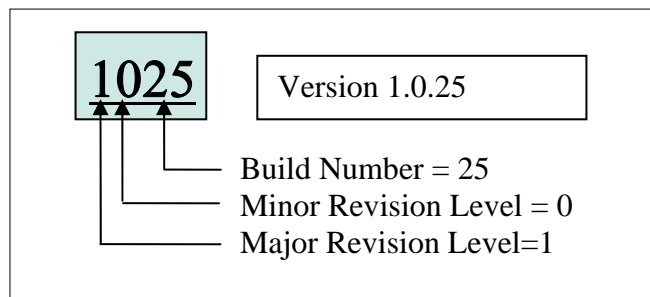

After 2-3 seconds, the display will then display the number of power on/off cycles which have occurred and the underline will be turned off. This count is not the number of shots or pulses which have been generated by the module, but instead is the number of times the module has gone from an inactive state to an active state. This number is incremented each time the timer goes through its startup routines.

After a short delay, the timer will transition to a repeating operational display mode. This is described below.

## Operational Display

In this mode, the timer displays a sequence start indicator followed by up to three timer values depending on the operating mode and the configuration which was applied at the factory. These are described below.

### Sequence Start Indicator

In order to indicate the beginning of the display sequence, the timer displays the Sequence Start Indicator. The display briefly shows the following readout: 

### First Readout Value

The next value displayed is the module hour counter. This displays the number of hours the module has been operating. If the number of hours exceeds 9999, then the display will scroll to the left to show the additional digits.

### Second Readout Value

The second value displayed in the sequence can be one of two values depending on the operating mode. If the pump head is being operated in CW mode, then the display will again report the number of operating hours. If the module is being pulsed, then the display will show the number of shots or pulses which the module has generated. See the description below for an explanation of the meaning of the shot counter display.

### Optional Third Readout Value

The third value which is displayed is an optional value which is configured at the factory when the module is built. Contact NGAS CEO for information about the values which can be selected. If no value is selected, this display value is skipped

and the display cycle starts over. Typically, the module will be programmed to display the on/off cycle count in this third position.

After displaying all of these values, the cycle will repeat with the display of the sequence start indicator.

## Shot Count Display:

The shot counter display is capable of displaying a very large number of shots with 3 significant figures. The first 3 digits of the shot count represent the first 3 digits of the number of shots. The fourth digit represents the number of zeros to place behind this 3 digit number. For example, if the readout showed **8385** this would represent approximately 83,800,000 shots. If the value shown has a line beneath it, such as **1480** then the fourth digit should be increased by 10 to determine the number of zeros. In this case, the shot count would be approximately 1,480,000,000,000

# Closed Loop Chiller

The single most common cause of laser module return for repair involves customer damage. More than one third of all customer damaged laser modules involve cooling problems. Coolant problems almost always require the replacement of the diode arrays - the single most expensive component in NGAS CEO laser modules. Read the following section carefully to avoid damaging arrays.



**CAUTION** Do not operate module without cooling. Inadequate heat dissipation will seriously damage the laser diodes and will void warranty.

Table 3-1. Cooling System Requirements

<b>Chiller and Cooling System Requirements</b>
Optishield Plus™/distilled water coolant (10% Optishield Plus™, 90% distilled water) <sup>1, 2</sup>
Coolant circulated at 50 psi.
Filter connected between chiller and inlet on module <sup>3, 4</sup>
Module first in coolant loop <sup>5</sup>
Chiller Heat Capacity > Power Consumption (Table 1-2)
Flow sensor (connected to coolant interlock on drive electronics) <sup>6</sup>
<p><sup>1</sup> Clean coolant is important to keeping coolant lines from clogging. Untreated tap water is not an acceptable coolant and may cause damage. Optishield Plus™ is the recommended coolant. It is made from DI water with additives to control the pH. By using DI water in the solution, scale will not form in the cooling loop. It contains biocide to prevent algae growth and corrosion inhibitors to protect yellow metals and aluminum.</p> <p><sup>2</sup> Optishield Plus is available from Opti Temp, Inc (<a href="http://www.optishield.net/home.php?cat=103">http://www.optishield.net/home.php?cat=103</a>).</p> <p><sup>3</sup> The filter should be capable of removing particles 5 µm or larger.</p> <p><sup>4</sup> Every month, or whenever the filter is changed, the coolant should be drained. The chiller should then be cleaned. The filter should be changed more frequently if the chiller manufacturer recommends a shorter interval.</p> <p><sup>5</sup> This ensures the cleanest, coolest coolant passes through the diodes (the most expensive component of most lasers).</p> <p><sup>6</sup> When not using CEO drive electronics, verify that flow sensor interrupts current to diodes less than 500 milliseconds after a low flow condition occurs.</p>



Table 3-2. Avoid with Chillers

<b>Avoid with Chillers</b>
Untreated De-ionized water <sup>1</sup>
Iron or aluminum parts in plumbing loop
Operation below air condensation temperature

<sup>1</sup> CEO recommends chiller water have a resistivity of less than 1.0 MΩ. Deionized water can be used if the resistivity is closely monitored and the coolant loop does not have iron or aluminum parts.

## Operating the Chiller



**WARNING.** Do not operate module without cooling. Inadequate heat dissipation will seriously damage the laser diodes and will void warranty. If you notice coolant in the immediate vicinity of the module, shut the laser system down immediately. Check to see if the coolant is coming from the module. If so, return the module for repair. If not, repair the source of the leak and allow the module to dry thoroughly before resuming operation.

The REA-Series module has a coolant loop to prevent thermal damage to the laser diodes. The diodes should be kept at approximately 20-35 °C. See the final test report for optimum temperature and flow rate settings. Operating the laser diodes for even a short period of time (less than 1 second) without coolant will cause permanent damage. To help prevent this, all NGAS CEO drive electronics are equipped with a coolant interlock. This interlock interrupts drive current to the diodes when coolant flow rate drops below set point. For this to function properly, a **flow sensor** must be used in the coolant loop. It is a good idea to test the function of the flow sensor before firing when first setting up the laser system. This can be accomplished by setting the drive current to a very low level (~ 1 A) then attempting to fire the laser with the chiller off. In case interlock does not function correctly, be prepared to manually turn off laser. By testing the interlock with a minimal current, the risk to the laser diodes is minimized.



**WARNING.** Do not operate the coolant system below air condensation temperature (dew point) at the laser head. Condensation on the diode arrays can seriously damage the laser head and will void the warranty. Consult a Cutting Edge Optronics field service engineer if you have any questions.

## Air Condensation Temperature

The air condensation temperature (or dew point) is the highest surface temperature that allows water to form from the ambient water vapor. The dew point is dependent

on the surrounding air temperature and relative humidity. If a surface (such as a laser diode) is cooled at or below the condensation temperature, water may collect on that surface. A formula for calculating dew point is given below, along with a calculated table. All temperatures are given in Celsius.

---

**Condensation Temperature**

---

$$T_d = \frac{237.7 \times \alpha(T, RH)}{17.27 - \alpha(T, RH)} \quad \alpha(T, RH) = \frac{17.27 \times T}{237.7 + T} + \ln\left(\frac{RH}{100}\right)$$

where

---

T is the ambient air temperature in degrees Celsius ( $0 < T < 60$ )

---

RH is the relative humidity in percent ( $1\% < RH < 100\%$ )

---

$T_d$  is the air condensation temperature

---

For example, suppose your chiller is running at 22 °C and the ambient air temperature near the laser is 28 °C (82 °F). Referring to Figure 3-3 and Table 3-3, find the intersection of the 28 °C air temperature and the curve for the 22 °C diode temperature. At a relative humidity of 70 percent or greater, condensation will form on the laser diodes.

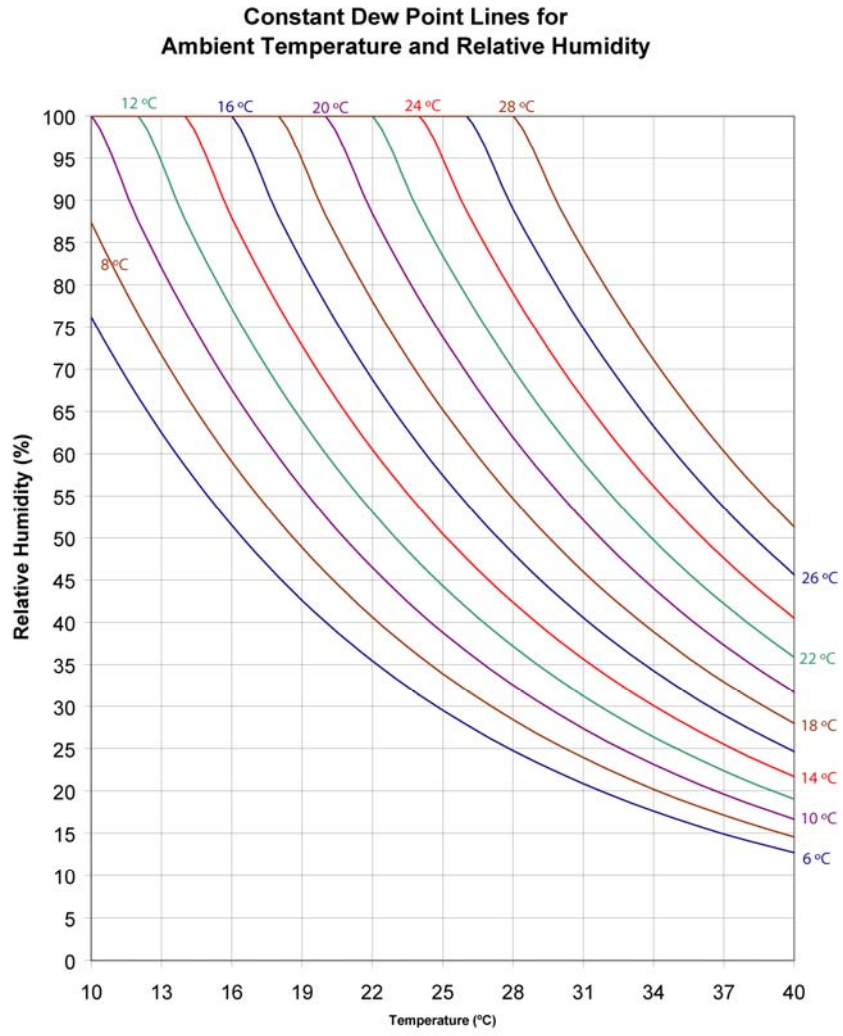

Figure 3-3. Constant Dew Point Lines for Ambient Temperature and Relative Humidity

Table 3-3. Table of Air Condensation Temperature at Given Ambient Air Temperature (Celsius) and Relative Humidity (percent)

<b>Relative Humidity</b>											
	1%	10%	20%	30%	40%	50%	60%	70%	80%	90%	100%
10	-43.9	-20.2	-11.9	-6.8	-3.0	0.1	2.6	4.8	6.7	8.4	10.0
12	-42.6	-18.7	-10.3	-5.0	-1.2	1.9	4.5	6.7	8.7	10.4	12.0
14	-41.4	-17.1	-8.6	-3.3	0.6	3.7	6.4	8.6	10.6	12.4	14.0
16	-40.2	-15.6	-7.0	-1.6	2.4	5.6	8.2	10.5	12.5	14.4	16.0
18	-39.0	-14.1	-5.3	0.2	4.2	7.4	10.1	12.4	14.5	16.3	18.0
20	-37.8	-12.5	-3.6	1.9	6.0	9.3	12.0	14.4	16.4	18.3	20.0
22	-36.6	-11.0	-2.0	3.6	7.8	11.1	13.9	16.3	18.4	20.3	22.0
24	-35.4	-9.5	-0.4	5.3	9.6	12.9	15.7	18.2	20.3	22.3	24.0
26	-34.2	-8.0	1.3	7.1	11.3	14.8	17.6	20.1	22.3	24.2	26.0
28	-33.0	-6.5	2.9	8.8	13.1	16.6	19.5	22.0	24.2	26.2	28.0
30	-31.8	-4.9	4.6	10.5	14.9	18.4	21.4	23.9	26.2	28.2	30.0
32	-30.6	-3.4	6.2	12.2	16.7	20.3	23.2	25.8	28.1	30.1	32.0
34	-29.5	-1.9	7.8	13.9	18.5	22.1	25.1	27.7	30.0	32.1	34.0
36	-28.3	-0.4	9.5	15.7	20.2	23.9	27.0	29.6	32.0	34.1	36.0
38	-27.1	1.1	11.1	17.4	22.0	25.7	28.9	31.6	33.9	36.1	38.0
40	-26.0	2.6	12.7	19.1	23.8	27.6	30.7	33.5	35.9	38.0	40.0

If required to operate a laser in conditions near to the condensation temperature, take precautions to keep the REA Series module dry. The module should be operated inside an area that is purged with nitrogen (N<sub>2</sub>) or encased in a sealed enclosure with a desiccant.

## High Voltage DC Power Supply

The REA-Series requires a high voltage DC power supply to provide electricity to the laser diodes. The chosen power supply should be regulated. Unregulated supplies tend to either drop below the minimum voltage required to maintain regulation, or to sit at an unnecessarily high voltage at lower currents, causing FET overheating.

The chosen power supply should be capable of providing the end of life current mentioned in the specifications table 1-2. The power supply must also be capable of providing the voltage listed in table 1-3 with an additional 2 volts for FET turn on. CEO Drivers can tolerate a large amount of ripple, since the pass FET typically filters this out. However, ripple should not exceed +/- 0.5 volt at full output current.



**WARNING.** Hazardous voltages are present during normal operation. Before removing the cover, the power source should be disconnected and a period of 20 minutes allowed for the discharge of stored capacitance. Use a voltmeter to verify all electronics are discharged before touching or grounding of electrical connections.

---

## Chapter 4: Installation and Operation

NGAS CEO recommends using the eDrive diode drive electronics, an external power supply, and a Polyscience chiller to operate the REA Series module (see Chapter 1 for chiller capacities). The following chapter contains step by step procedures detailing the installation and operation of the REA Series module with these peripherals. This chapter covers:

- REA Series Laser Module Assembly and Connections
- Closed Loop Water Chiller Assembly
- Starting the Laser System
- Pre-start Conditions
- Turning on the Laser System
- Powering the REA Series Module
- Standby Condition
- Turning Off the System

The purchaser is responsible for any loss and injury during installation and use of the REA Series module. NGAS CEO recommends that a qualified service technician install and maintain the laser. If you intend to service the laser yourself, please follow the following procedures.

# REA Series Laser Module Assembly and Connections

---



**CAUTION.** The module is susceptible to damage due to electro-static discharge (ESD). Always use proper ESD control devices when handling the module.

See Module Connection Diagram (figure 4-1).

1. Check to make sure the AC power switch located on the rear panel of the eDrive Laser Diode Controller is in the **OFF** position.
2. Connect the Array Drive lugs from the rear of the eDrive to the power lugs on the side of the REA module. (Positive to positive and negative to negative.)



**ELECTRICAL WARNING** The voltages in this system can be harmful or even lethal. Whenever handling or servicing the laser, always disconnect the power cord to the power supplies and drivers. Use a voltmeter to verify all electronics are discharged before touching or grounding of electrical connections.

3. Connect the lab door interlock switch (or other interlock used) to the **Interlock** connector on the rear of the eDrive. If multiple interlocks are needed, be sure all interlocks are connected in *SERIES* to this port. If no remote interlocks are used, short the connection to allow for normal laser operation.
4. Prior to connecting an external power supply, check to make sure the AC power switch of the external power supply is in the **OFF** (O) position. Then, connect the output of the supply to the input power lugs of the eDrive located at the upper left of the rear panel.
5. Verify the eDrive has clear space in rear and on each side of unit to allow proper air flow.
6. Verify shroud over eDrive power lugs is in place to prevent human access to dangerous voltage.
7. Plug the eDrive and external power supply cords into the appropriate facility power.

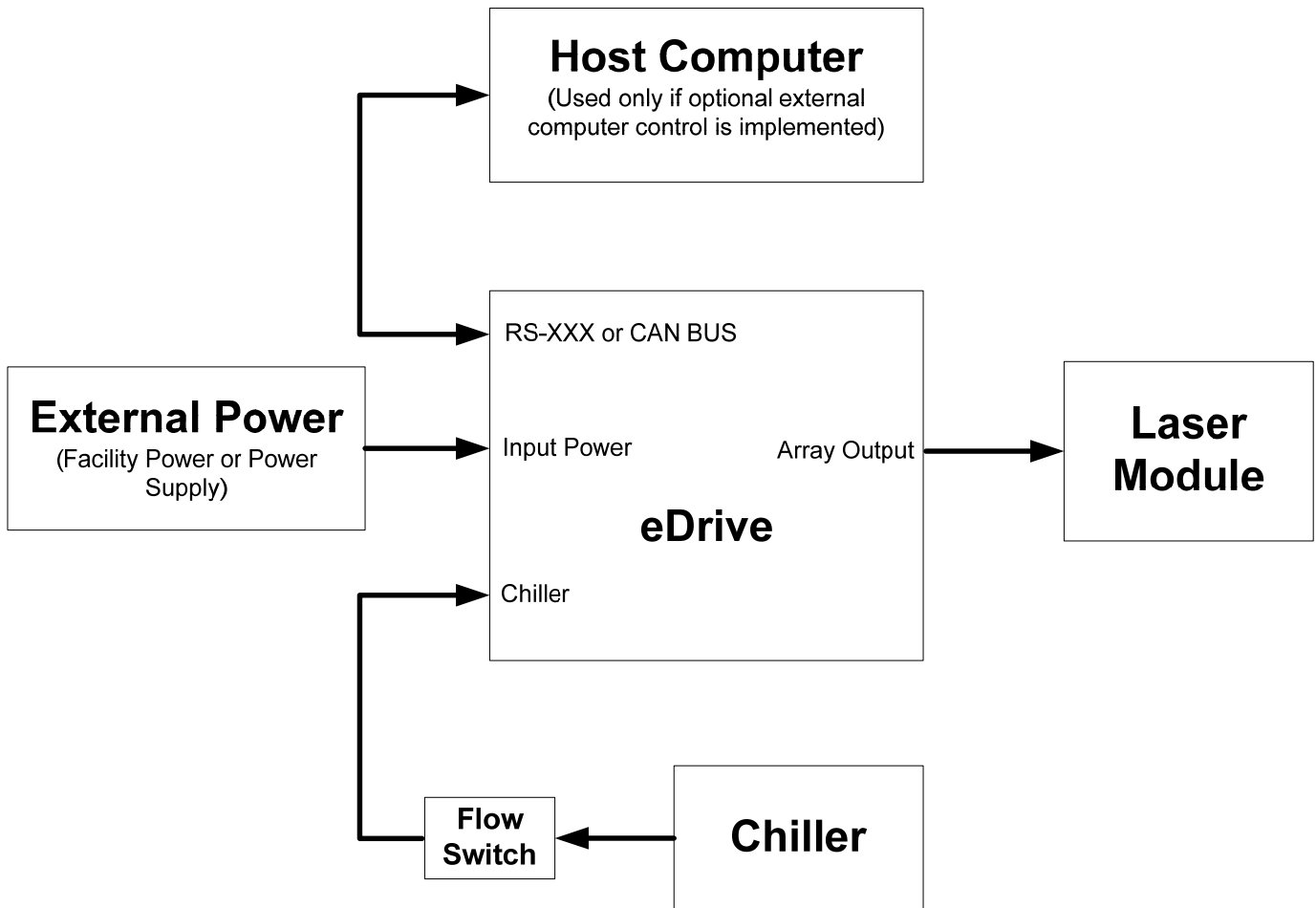

Figure 4-1 Connection Diagram

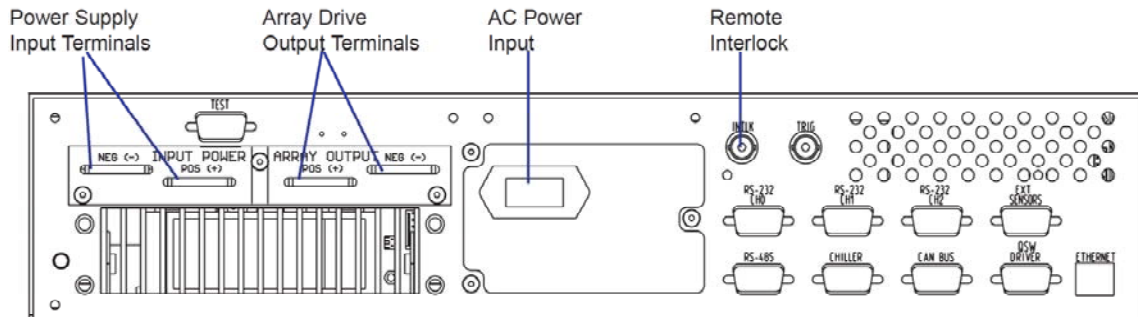

Figure 4-2 eDrive Rear Panel



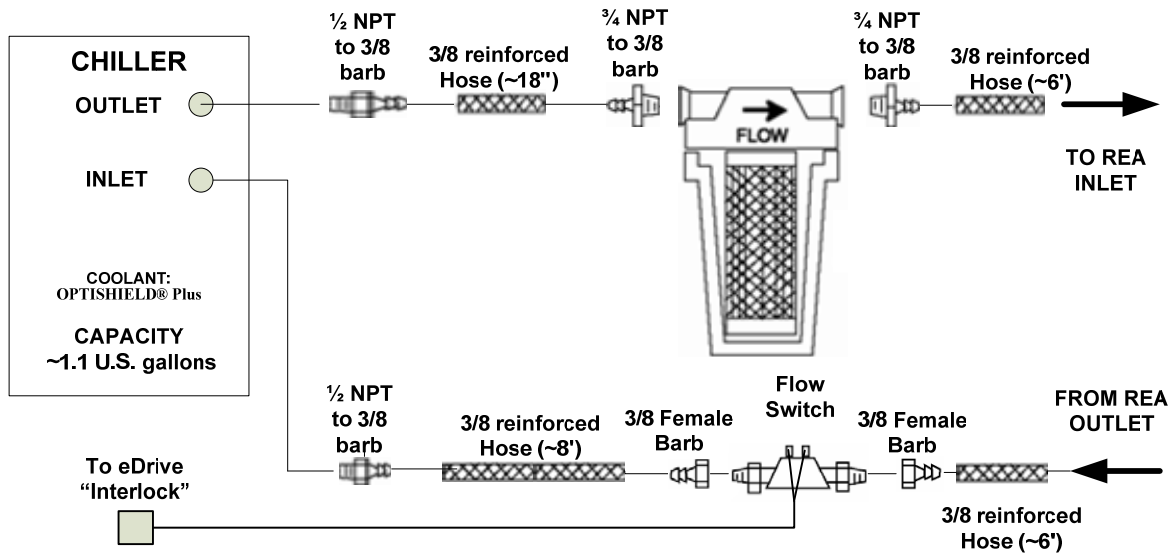

Figure 4-3 Chiller Assembly Drawing

## Closed Loop Water Chiller Assembly

1. Place the chiller on the floor near the REA Series laser module. Refer to the chiller instruction manual for power requirements, settings and instructions on how to set up the chiller.
2. Attach the cooling lines (included with the plumbing accessory kit) to the hose barb fittings on the chiller and on the REA Series laser module. Remember to attach the water filter between the chiller and the laser head. The filter may be attached to the back of the chiller or to some other stable mounting point (i.e. wall).

The standard plumbing arrangement for a typical closed loop chiller (including hose diameters) is shown in Figure 4-3. The input/output coolant connections on the REA Series are polarized. Coolant flow direction is important, see Figure 1-1 for coolant inlet and outlet orientation for the REA Series module.



**CAUTION.** Do not use de-ionized (DI) water in the closed loop chiller based system. If you must use DI water, monitor the resistivity (less than 1.0 MΩ) closely and avoid iron or aluminum parts in the coolant loop.

3. Fill the chiller reservoir and filter housing manually with coolant (10% Optishield Plus™, 90% distilled water) It is made from DI water with additives to control the pH. By using DI water in the solution, scale will not form in the cooling loop. It contains biocide to prevent algae growth and corrosion inhibitors.



**CAUTION.** Do not allow chiller to fill the filter housing, as air can become trapped within the system.

4. Power on the chiller
5. Make sure no air remains trapped in the lines resulting in a positive back pressure when chiller is turned off. Positive back pressure can hold the flow switch closed even though flow is not being supplied to the laser module. Air is trapped in the lines if coolant level drops when chiller is turned on and then rises when turned off. Failure to heed this warning may result in the destruction or serious damage to the device, and will void the product warranty.
6. Verify the pressure gauge located on the front panel of the chiller reads approximately 50 psi. If it does not, adjust the bypass valve on the rear of the chiller. Minimum coolant flow is one gallon per minute. See final test report for optimum flow rate, which should be ~2 gallons per minute.
7. Verify the temperature located on the front panel of the chiller reads appropriately. Optimum temperature is listed on the final test report but will be between 20 °C -35 °C.
8. Connect coolant flow switch to **coolant interlock** on rear of eDrive diode driver. When connecting the coolant flow switch, make sure that it is connected to the return line of the chiller and the arrow located on the top of the switch is pointing in the direction of coolant flow.

## Starting the Laser System

---

### Pre-start Conditions

1. Wear laser safety goggles which protect user from 1064 nm (fundamental) and 808 nm radiation.
2. Position the REA Series module in a laser cavity such the output will be directed toward a safe target.
3. Verify that the system is correctly assembled.
4. Verify that the rod faces are clean and not capped or covered.
5. Verify that the filter on the closed loop chiller is connected to the inlet hose barb.
6. Switch the Closed Loop Chiller to the **ON** position. Verify coolant flow from chiller.



**WARNING.** Do not operate coolant system below air condensation temperature (dew point) at laser head. Condensation on the diode arrays can seriously damage the laser head and may void warranty. Consult a CEO field service engineer if you have any questions.

## Turning The Laser System On

1. Verify coolant temperature and flow rate are correct.
2. Turn power switch on external power supply to **ON** position. Set the voltage to the voltage shown on the data sheet, and set the current to supply the required amount for the application.
3. Turn the AC power switch on rear of the eDrive to the **ON** position.
4. Turn the Key switch to the **ON** position.
5. Press the main AC **POWER** switch of the eDrive, located on the front panel.
6. Before applying current to diodes, shut off chiller to verify that the Coolant Fault interlock comes on within 1 second.
7. Restart the chiller. Select **Clear** and verify the error display is no longer present.

## Powering the REA Series Module

1. From the eDrive main menu, select **Channel Setup ▶ Channel 1 ▶ Set Current Limit**. Use the selection knob to set your maximum current amplitude to a value considered safe for the intended module. The eDrive will not allow the current amplitude to be set higher than the limit.

REA-1C2H modules should never be run with more than 32 Amps and REA-1C4H should never be run at more than 50 A. However to prevent premature diode degradation, you may wish to set this limit at the beginning of module life to 5 Amps greater than the recommended operating current.

2. From the main menu, select **Channel Setup ▶ Channel 1 ▶ Set Current**. Use the selector knob to select a low current level of approximately 10A.
3. Press **EMISSION**. After a few warning beeps (approximately 4 second delay), the eDrive begins to drive current to the module.
4. Slowly begin to adjust the current amplitude setting until the desired current level is achieved. Rate increase in current should not exceed 3A/s (For initial use, see final test report for current.)
5. Using an infrared viewer or phosphor card continue increasing the current checking for output at the laser threshold current indicated on the final test report.
6. Continue increasing the current until the desired output is obtained or until the current reaches approximately 5 A greater than the current used during the last time an acceptable laser output was achieved. (For initial use, see final test report for current.)
7. If you cannot achieve desired output within 5 A, contact NGAS CEO for assistance.

## Standby Condition

---

If you are finished using the module but want to use it again within the next hour, it is best to go to “standby”. To go to standby from a lasing condition, press the **EMISSION** button on the eDrive Laser Controller. In this condition, the drive current to the laser diode shuts off but the closed loop chiller maintains the optimum diode temperature.

To resume lasing, press the **EMISSION** button on the eDrive laser controller. Again an audible warning will sound for approximately 4 seconds prior to firing the laser.

## Turning Off the System

---

1. Press the **EMISSION** button to turn off drive current.
2. Close shutter (if installed).
3. Press the main AC **POWER** switch of the eDrive, located on the front panel. Hold down for approximately 5 seconds until the eDrive shuts down.
4. Switch the main AC power switch on the external power supply, located on the front panel, to the **OFF** position.
5. Turn the AC power switch on rear of the eDrive to the **OFF** position.
6. Using a voltmeter, verify voltage has discharged on module power lugs
7. Allow chiller to run for a couple of minutes (1-2 minutes).
8. Switch the closed loop chiller to the **OFF** position.
9. Turn the key switch on the eDrive to the **OFF** position.
10. Remove the key. Do not leave the laser accessible to people who are untrained in laser safety or operation.



**WARNING.** Hazardous voltages are present in this system during normal operation. Use a voltmeter to verify all electronics are discharged before touching or grounding of electrical connections.

## Chapter 5: Maintenance

The chapter contains information in these sections:

- Rod Removal and Replacement
- Rod Cleaning
- Leak Test Procedure
- Adjusting the Operating Current
- Cleaning the Chiller

## Rod Removal and Replacement

The only user serviceable part in the REA Series module is the Nd:YAG rod, which can be replaced by the user. YAG rods rarely break, frequent replacement may be a sign of another problem in the REA Series module. Contact Cutting Edge Optronics if you have any further questions.



**CAUTION.** The module is susceptible to damage due to electro-static discharge (ESD). Always use proper ESD control devices when handling the module.



**CAUTION.** Ensure gloves or finger cots are worn during this procedure and that it is carried out in a clean environment, preferably under a laminar flow hood.

### REA-XXXX-001X Configuration

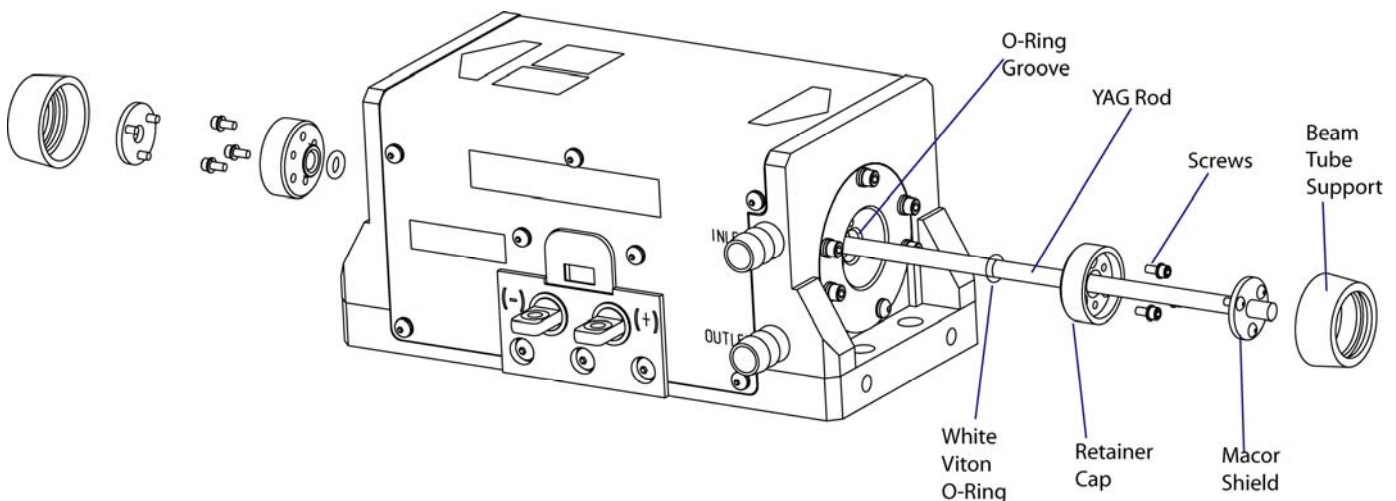

Figure 5-1 Rod Replacement Drawing, REA-XXXX-001X

1. Remove four fasteners releasing Macor shields.
2. Remove the two retainer caps from the ends of the module.



**CAUTION.** Use extreme caution during the remaining steps of this procedure to insure that the rod faces and/or coatings are not damaged. Never use a tool that can scratch the rod on the O-rings.

3. Extract one of the O-rings that hold the rod in place using a dental pick or other similar tool. Stick the sharp end of the dental pick into the O-ring and pull away from the pump module. New O-rings will be used during the installation of the

new rod. Be very careful not to damage the rod ends, or barrel, with the extraction tool.

4. Remove the rod by applying slight pressure in order to break the O-ring seal on the opposite end. Partial extraction of the O-ring on the opposite end may be needed. If necessary, loosen the O-ring with the dental pick. Once again, be careful not to damage the rod ends, or barrel.
5. Unwrap the new rod and inspect the end faces.
6. Obtain two #007 white Viton O-rings when using a 4mm diameter rod, two #008 white Viton O-rings when using a 5mm diameter rod, or two #010 white Viton O-rings when using a 6.35mm diameter rod.
7. Place one of the corresponding O-rings over one end of the rod. Position the O-ring inside the O-ring groove on the end plate.
8. Insert the opposite end of the rod into the corresponding hole in one end of the module until it protrudes from the hole in the opposite end. Center the rod. The rod is very fragile. Be careful not to chip or scratch the rod while inserting it.
9. Place one of the retainer caps over the end of the rod with the O-ring. Attach via the hardware removed during disassembly.
10. Place the second white O-ring over the opposite end of the rod. Slide O-ring along rod into O-ring groove in endplate.
11. Inspect this rod end for cleanliness. If needed, clean the end of the rod with methanol and cotton swabs
12. Attach the second retainer cap onto the pump module.
13. Position the rod equidistant from each end of the pump module using the soft end of a cotton swab.
14. Reinstall Macor shields. Ensure that the gap is minimal between Macor shield and laser rod. The Macor shields protect the retainer nut and O-rings from stray laser radiation.
15. Inspect both rod ends for cleanliness. If necessary, clean the ends of the rod with a puff of dry nitrogen or moisture-free canned air.
16. Leak test according to the following procedure. Alternately, turn on the chiller and allow coolant to flow for approximately 20 minutes. Examine pump module for leaks.
17. If pumphead leaked: first fix the leak, then test again for leaks, finally allow module to dry thoroughly before lasing. Firing wet diodes will permanently damage them.

## REA-XXXX-002X Configuration

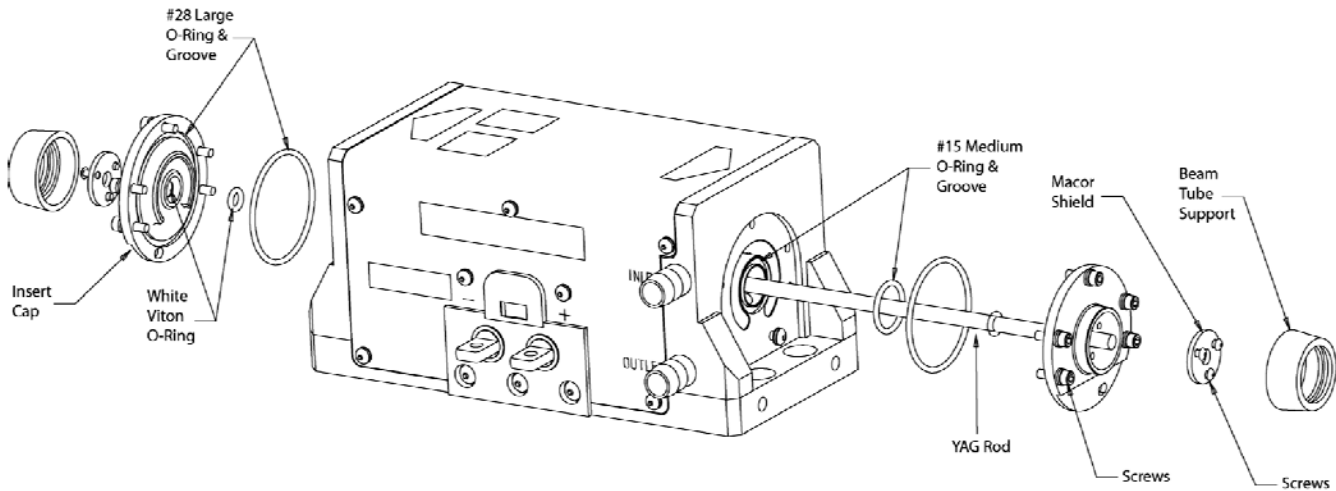

Figure 5-2 Rod Replacement Drawing, REA-XXXX-002X

1. Remove beam tube supports and the Macor shields from both ends of the rod.



**CAUTION.** Use extreme caution during the remaining steps of this procedure to insure that the rod faces and/or coatings are not damaged. Never use a tool that can scratch the rod on the O-rings.

2. Starting with the end of the module without the hose barbs apply methanol to the rod o-ring.
3. Remove the six screws that hold the insert to the endplate and then slowly rotate and pull the insert off the rod.
4. Moving to the other end of the module with the hose barbs remove the six screws holding the insert to the endplate and pull the insert and rod out of the module.
5. Apply methanol to the rod o-ring and remove the second insert.
6. Remove rod from its packaging and inspect end faces under 50X magnification.
7. Inspect rod o-rings in the center of the inserts, if no damage is found reuse the original o-rings but if damage is found obtain two #10 white o-rings if using a 6.35mm diameter rod, two #8 white o-rings if using a 5mm wide rod or two #7 white o-rings if using a 4mm wide rod and replace the original o-rings.
8. Each insert has one large o-ring groove on the surface near the edge of the insert this is the inside surface of the insert, Figure 5-3 shows correct installation of the #28 black o-ring into this groove.
9. Lubricate both white o-rings in the center of the inserts and both #28 black o-rings with the syringe of methanol.



10. Place a #15 black medium o-ring in the matching groove on the right endplate of the module, as shown in Figure 5-3, that has the two hose barbs and then lubricate with the methanol syringe.

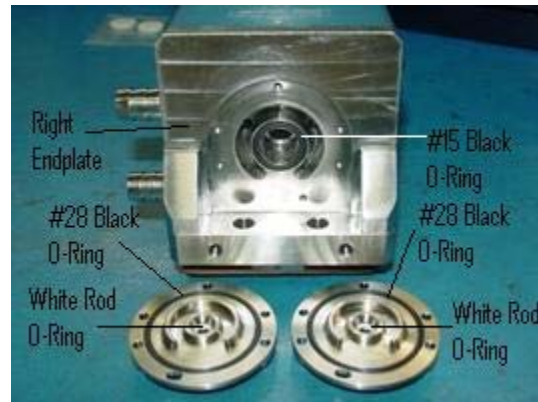

Figure 5-3 REA-XXXX-002X O-rings

11. Push the rod through the white o-ring in the center bore of one insert from the inside surface side of the insert until it sticks past and out the other side about 1/8" making sure not to shave or cut the white o-ring.
12. Holding the rod with one insert on it carefully slide the end without the insert in to the center bore of the hose barbed end plate until the rod comes out the other end of the module, being careful not to hit the rod end on the endplate.
13. Holding the insert up against the hose barbed endplate so it is flat and level place a gloved fingertip over the rod to keep it from being pushed out in step 14.
14. With one hand held as stated in step 13, use the other hand to push the second insert onto the exposed rod end making sure the white o-ring is not damaged as the rod passes through the center bore of the insert and the #28 black o-ring faces the endplate.
15. Once the inserts are pushed safely onto the rod ends they should lay flush with each of their endplates of the module with the #28 black o-rings as the seal between the two pieces.
16. Fasten each of the two inserts to their endplates with five #4 sized 3/8" SHC Screws and one #4 sized 3/8" BHC Screw that goes in the slotted hole, shown in Figure 5-3, of each insert.
17. Clean the rod ends at 50x with canned air and methanol soaked q-tips
18. Reattach the Macor shields.
19. Double check the rod ends with a microscope after the Macor shields are in place to ensure the rod ends are still clean. Then replace the beam tube supports.

## Rod Cleaning



**CAUTION.** Ensure gloves or finger cots are worn during this procedure and that it is carried out in a clean environment, preferably under a laminar flow hood.

1. Blow optical surface with dry nitrogen
2. Remove four fasteners releasing Macor shields.
3. Using hemostats and lens tissue, wetted with acetone or methanol, wipe the rod face in a circular motion from the center of the rod to the edges.
4. Inspect the rod for cleanliness.
5. Reinstall Macor shields. Ensure that the gap is minimal between Macor shield and laser rod. The Macor shields protect the retainer nut and O-rings from stray laser radiation.

## Leak Test Procedure

Laser diodes are very sensitive to water damage. If you have access to pressurized nitrogen and a pressure gage, you can test for leaks without exposing the diodes to water.

1. Attach a nitrogen source to one of the coolant ports on the module being tested (test article) and attach the termination valve to the other coolant port on the test article.
2. Close the termination valve.
3. Open the inlet valve and adjust the regulator to obtain 80 psi on the pressure gauge.
4. Close the inlet valve. Wait.
5. Return after 30 minutes and record pressure on the gauge. Subtract this pressure from starting pressure of 80 psi to get the pressure drop over 30 minutes.
6. Pass/Fail requirements: if the pressure drop is greater than 3 psi FAIL, if the pressure drop is less than 3 psi PASS.

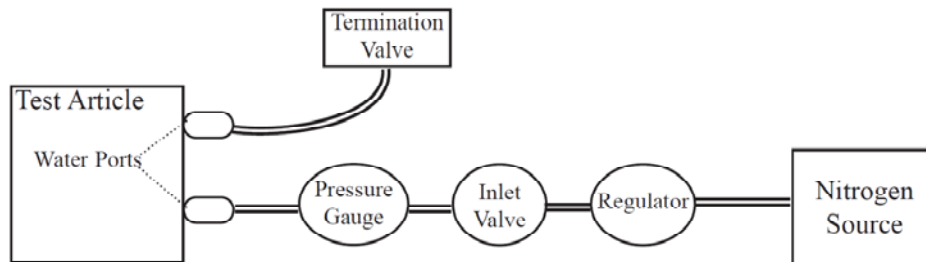

Figure 5-4 Nitrogen Leak Test Layout

## Adjusting the Operating Current

---

The specification for laser module optical output is provided in the final test report delivered with the system. During its early lifetime, the laser diodes will deliver this specified power at or below 25 A of current for 1C2H modules or 45A. for 1C4H modules. Due to the high average powers of the diode bars used in your NGAS Cutting Edge Optronics laser module, it is reasonable to expect the diode array to gradually degrade with use.

### Determining when the current limit requires adjustment:

Make sure the temperature is at the correct set point. If the temperature is incorrect low output power can result, leading to unnecessary current increases. Check to make sure the rod faces are clean. If the rod faces are dirty low output power will result, leading to unnecessary current increases. Check to make sure the coolant and filter are clean. If the coolant is dirty, deposits accumulate on the Nd:YAG rod, which prevents absorption of diode light. This results in low output power, leading to unnecessary current increases. If the temperature is correct and the rod faces and coolant are clean, yet the output power is still low, the operating current may need to be slightly raised. Contact your NGAS Cutting Edge Optronics field service engineer if you have any doubts.



**CAUTION.** Raising the current limit before it becomes necessary can severely shorten diode lifetime.

### Adjusting the Temperature Set Point for the Re-circulating Water Chiller

The temperature set point for the water chiller was determined at NGAS CEO and indicated on the Final Test Report. Normally the temperature will not need adjustment. It is possible however, that this adjustment may be recommended by your Cutting Edge Optronics field service engineer during the later part of the laser diodes' lifetime and after several current increases. Increasing the diode drive current increases the heat load on the diode, resulting in a shift in diode wavelength. In order to compensate for this shift a slight adjustment, most likely colder, of the temperature set point on the recirculation water chiller may be required. Changing the temperature set point will change the output wavelength of the laser diode; this adjustment should be done in one degree Celsius increments. Look for an increase in optical output power on an external power meter. Wait a few minutes between each adjustment allowing the chiller to stabilize. Continue until you obtain the maximum possible power.



**WARNING.** Do not operate coolant system below air condensation temperature (dew point) at laser head. Condensation on the diode arrays can seriously damage the laser head and may void warranty. Consult a CEO field service engineer if you have any questions.

## Cleaning the Chiller

---

The cooling fluid should run for a maximum period of 1 month after which the system should be drained, cleaned and refilled with clean coolant. The filter on the closed loop system should be monitored weekly. The system should also be drained, cleaned and refilled with clean coolant if any discoloration of the filter occurs.

### Chemicals and Supplies Needed

- 3% Hydrogen Peroxide solution sufficient to fill the system.
- Optishield Plus™ and distilled water solution (10% Optishield Plus™, 90% distilled water).
- Distilled water, sufficient to fill the system.
- Two replacement particle filters (NGCEO part # 37023165).

### Cleaning Procedure

1. Drain chiller and clean any residue or contamination in the reservoir with the use of a bottle brush or alcohol wipes.
2. Using a filter housing wrench, dismantle the particle filter housing. Empty the coolant trapped in the filter housing into a container for later disposal.
3. Dispose of the expired particle filter and clean any residue or contamination from the inside of the filter housing. Install a new filter in the housing.
4. Refill with distilled water and circulate for 5 minutes.
5. Drain system completely as detailed in steps 1 and 2.
6. Fill the chiller with a 3% solution of Hydrogen Peroxide. Care should be taken to ensure that the mixture completely fills to the top of the reservoir to ensure all wetted surface areas of the chillers are cleaned. Cycle the chiller on and off. Top off the reservoir as necessary to ensure it is full of the cleaning solution. Ensure that the cap of the chiller reservoir is loose or remove it completely to allow gas to escape from the system.
7. Circulate the cleaning solution through the system including the diode pump module for 40 minutes.
8. Drain the cleaning solution mixture from the chiller as detailed in steps 1 and 2.

9. Refill and circulate distilled water for 5 minutes and drain. Ensure that the cap of the chiller reservoir is loose, or remove it completely to allow gas to escape from the system.
10. Drain the chiller and dispose of the filter.
11. Disconnect the chiller from the diode pump module and blow out water from the diode pump module coolant loop prior to refilling the chiller coolant reservoir.
12. Reconnect the diode pump module coolant loop.
13. Install new 5 micron filter into housing.
14. Record cleaning date on sticker with a one-month reminder to drain & clean the system. Affix sticker to chiller (or cabinet).
15. Refill the chiller reservoir with Optishield plus and distilled water coolant following the manufacturer's directions. Run for 30 minutes with the cap loose to allow gas to escape from the system.
16. Secure the reservoir cap. It should have a 0.125 inch (~3mm) diameter hole in it to allow the cooling system to vent. A hole should be drilled into the reservoir cap if one is not already present.
17. Chiller ready to use.

---

## Chapter 6: Service

At Northrop Grumman Aerospace Systems Cutting Edge Optronics, we are proud of the durability of our products. Our manufacturing and quality control processes emphasize consistency, ruggedness, and high performance. Nevertheless, even the finest instruments break down occasionally. We believe that the reliability record of our instruments compares favorably with that of our competition, and we hope to demonstrate our superior service by providing dependable instruments and, if the need arises, service facilities that can restore your instrument to peak performance without delay.

When calling for service in the U.S., dial (636) 916-4900. To phone for service in other countries, contact your sales agent.

This chapter provides reference to types of customer service needs:

- Contacting customer service
- Return the instrument for repair

## Contacting Customer Service

---

To expedite your service needs, please complete the questionnaire in *Appendix A: Customer Service* **before** you contact Cutting Edge Optronics Customer Service. Complete the questionnaire with as much detail as possible and retain a copy for your records.

E-mail or fax the form to Cutting Edge Optronics (refer to the second page of this manual for contact information) and notify your customer service representative that it has been sent.

## Return the Instrument for Repair

---

A return merchandise authorization (RMA) *is required* prior to shipping any instruments to Cutting Edge Optronics. Contact Cutting Edge Optronics or your local distributor for RMA and shipping instructions.



**CAUTION.** Failure to obtain proper shipping instructions may result in damage to the instrument.

Use the packing boxes supplied by Cutting Edge Optronics to ship your instruments. If shipping boxes have been lost or destroyed, replacements are available for a nominal charge from Cutting Edge Optronics.

Remove all coolant from module by blowing dry air through it for 20 minutes, prior to packaging for shipment. Place a shorting connector across the electrical connector (see example Figure 1-1). Place module in a sealed bag inside shipping container. Place some form of desiccant in bag with module.



**WARNING.** Damage from residual water due to condensation or expansion can be catastrophic to the diode arrays or laser rod if not dealt with properly. Such damage is excluded from warranty coverage.

## Appendix A: Customer Service

This form has been provided to encourage you to tell us about any difficulties you may have experienced while using your Northrop Grumman Cutting Edge Optronics instruments or user manuals. Call or write our customer service department to bring attention to problems that you may not have personally experienced. We are always interested in improving our products and manuals, and we appreciate all suggestions.

Date:

Name:

Company or Institution:

Department:

Address:

Module Model Number:

Serial Number:

Chiller Model Number:

Serial Number:

External Power Supply Model Number:

Serial Number:

eDrive Model Number:

Serial Number:

Module Manufacture Date:

Total Module Lifetime (hours):



# Questions

---

What is the coolant flow rate (GPM)?

---

What is the set temperature on the chiller (°C)?

---

What is the coolant pressure on chiller (PSI)?

---

What are the set current and actual current from eDrive (A)?

---

What is the external power supply voltage (V)?

---

What is the laser cavity configuration?

---

What is the measured CW power (W)?

---

When did the problem happen?

---

Have you changed any settings recently (yes/no)?

---

What are the changes made recently to the system?

---

---

---

---

Please describe the problem or module behavior as detailed as possible:

---

---

---

---

---

---

---

---

---

---

---

---

Suggestions

---

---

---

---

---

---

---

---

---

---

---

---

Email or send to:

**Northrop Grumman**  
**Cutting Edge Optronics, Inc.**  
**20 Point West Boulevard**  
**Saint Charles, MO 63301 USA**  
**Phone: (636) 916-4900**  
**FAX: 636-916-4994**  
**Email: st-ceolaser-info@ngc.com**

## Appendix B: System International Units

The following System International (SI) units, abbreviations, and prefixes are used throughout Cutting Edge Optronics user manuals:

Quantity	Unit	Symbol
mass	gram	g
length	meter	m
time	second	s
frequency	Hertz	Hz
force	Newton	N
energy	Joule	J
power	Watt	W
electric current	Ampere	A
electric charge	Coulomb	C
electric potential	Volt	V
resistance	ohm	$\Omega$
inductance	Henry	H
magnetic flux	Weber	Wb
magnetic flux density	Tesla	T
luminous intensity	candela	cd
temperature	Kelvin	K

Abbrv.		Prefixes
tera	$(10^{12})$	T
giga	$(10^9)$	G
mega	$(10^6)$	M
kilo	$(10^3)$	k
deci	$(10^{-1})$	d
centi	$(10^{-2})$	c
milli	$(10^{-3})$	m
micro	$(10^{-6})$	$\mu$
nano	$(10^{-9})$	n
pico	$(10^{-12})$	p
femto	$(10^{-15})$	f
atto	$(10^{-18})$	a

# Appendix C: Acronyms

Acronym	Description
ACGIH	American Council of Government Industrial Hygienists
ANSI	American National Standards Institute
AR	Anti-Reflective
AO	Acusto-Optical (type of Q-switch)
CDRH	Center for Devices and Radiological Health - U.S. Food and Drug Administration
CEO	Cutting Edge Optronics, Incorporated
CFR	Code of Federal Regulations
CW	Continuous Wave
DC	Direct Current
EO	Electro-Optical (type of Q-switch)
ESD	Electro-Static Discharge
FET	Field Effect Transistor
FDA	U.S. Food and Drug Administration
FWHM	Full Width - Half Max
GaAlAs	Gallium Aluminum Arsenide
GPM	Gallons Per Minute
HR	High Reflector
HV	High Voltage
IR	Infrared
KTP	Potassium Titanyl Phosphate
LBO	Lithium Triborate
MCC	Meters Concave
Nd:YAG	Neodymium-doped Yttrium Aluminum Garnet
NGAS	Northrop Grumman Aerospace Systems
NIR	Near Infrared

<b>Acronym</b>	<b>Description</b>
OSHA	Occupational Safety and Health Administration
PRF	Pulse Repetition Frequency
PSI	Pounds per Square Inch
SHG	Second Harmonic Generator
TTL	Transistor - Transistor Logic
VAC	Volts, Alternating Current